



**T1/T2 HYDRAULIC RAM
INSTALLATION & SERVICE HANDBOOK**



SERIAL NUMBER

NOTIFICATION

The information contained in this document is subject to change without prior notice.

Navico UK Ltd. shall not be liable for errors contained herein or for incidental or consequential damages in connection with the furnishing, performance, or use of this document.

No part of this work covered by the copyright hereon may be reproduced or otherwise copied without prior permission from Navico UK Ltd.

The information in this handbook was, to the best of our knowledge, correct when it went to press and Navico UK Ltd cannot be liable for any inaccuracies or omissions.

There may also be differences between the specifications in the handbook and the product as a result of ongoing development for which we accept no liability.

© 2008 Navico UK Ltd. All rights reserved.



Tel: +44 1794 518448
Fax: +44 1794 518077
www.bandg.com
sales@bandg.com
support@bandg.com

Navico UK Ltd.
Premier Way,
Abbey Park
Romsey, SO51 9DH
United Kingdom

LIABILITY AND SAFETY WARNINGS

Navico UK Limited accept no responsibility for the use and/or operation of this equipment. It is the user's responsibility to ensure that under all circumstances the equipment is used for the purposes for which it has been designed.

Warning: Electrical Hazard

This equipment uses high voltage electrical power. Contact with high voltages may result in injury and/or loss of life.

Warning: Calibration

The safe operation of this equipment is dependent on accurate and correct calibration. Incorrect calibration of this equipment may lead to false and inaccurate navigation placing the yacht into danger.

Warning: Operational Hazard

The Hydraulic Ram designed to assist in the navigation of your yacht. It is not designed to totally replace conventional navigation procedures and precautions and all necessary precautions should be taken to ensure that the yacht is not placed into danger.

The Hydraulic Ram is an aid to steering the vessel. It is the users responsibility to ensure the safe control and movement of the vessel at all times.

Caution: Electrical Supply

This equipment is designed for use with a power supply source of 12V dc. The application of any other power supply may result in permanent damage to the equipment.

Warning: Installation

Failure to install and maintain this equipment in accordance with the instructions contained in this Handbook could result in damage or injury.

This equipment must be installed and maintained by a person who is qualified to do so. This equipment is only for use with marine auto pilots within the limitations stated in the following pages.

This equipment meets the latest EMC (Electromagnetic Compatibility) standards required for use in the recreational marine environment. In order to ensure conformance and to prevent interference with electronic systems the unit must be properly bonded to earth and the supply cables screened. **DO NOT FLASH TEST!**

Beware of hot motor and solenoid components and the risk of entrapment from moving parts.

DESCRIPTION

B&G Rams combine a hydraulic cylinder, pump, motor, clutch and reservoir in one compact unit. A solenoid clutch is engaged to extend or retract the rod. The cylinder and its mounting are protected by integral relief valves. Overall adjustment is incorporated into the stroke of the cylinder - Ref. Installation details.

This document contains installation and service information for the following B&G part numbers:

- RAM-T1-12V
- RAM-T2-12V
- RAM-T2-24V

Pump and cylinder

Nominal pump flow and cylinder size are indicated on the rating plate. Check the voltage shown is correct for the output of your autopilot.

LOCATION

B&G Rams are designed for 'under deck' installations only.

Excessive temperature, vibration and fumes in the atmosphere can drastically reduce motor brush life.

It must be mounted securely and on a surface that is able to withstand the high thrusts generated.

As in common with other electrical equipment contact with water and excessive humidity must be avoided.

Any attitude of mounting may be used. Refer to the installation and technical data pages for further information.

DISMOUNTING THE UNIT FROM ITS BASE

- Take off the coil which is secured by a 17mm A/F nut.
- Undo and remove the Allen screw 'A' and the retaining plate 'B'.
- Withdraw the mounting pin 'C' which will release the base.

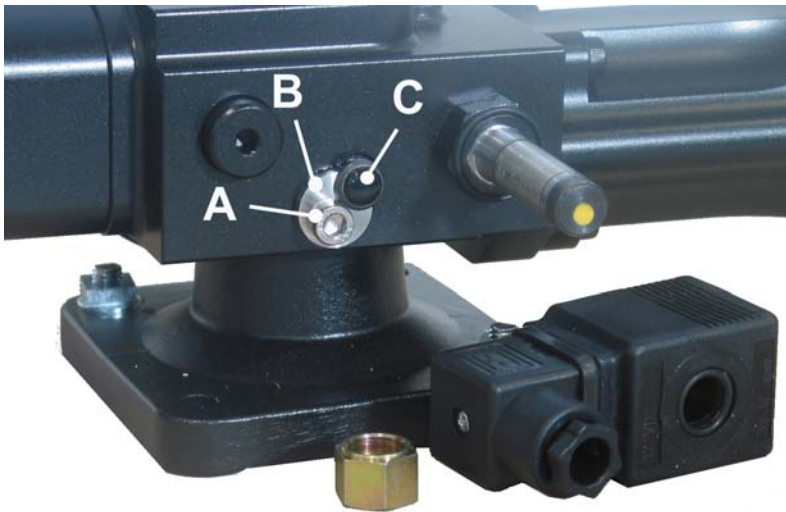

Note

The pin is a close engineered fit and if it proves difficult to remove take off the plastic cap from the head of the pin and insert screw 'A' into it.

It will then be possible to withdraw the pin using a pair of pliers or grips.

Important!

Avoid damage to the pin. Assembly is a reversal of the removal process. Ensure the plastic cap is re-fitted to the pin upon completion.

MAINTENANCE & SERVICE

With a minimum of moving parts and top quality precision engineering the Ram will give many years of trouble free service if the following points are adhered to.

- Keep the piston rod free from damage.
- Avoid exposing the unit to salt water.

Perform the following tasks on a regular basis.

- Check the security of the mounting base.
- Lubricate the mounting pin & rod end - use only a good quality marine grease that is compatible with nitrile seals.
- Examine all electrical connections.

Brushes

Inspect the motor brushes every 500 hours, or annually, for wear. Replacement motor brushes are available from your dealer. State the serial number of your unit when ordering.

Be sure to clean out all loose carbon before fitting new brushes. If fluid has entered the motor, degrease the brush gear and commutator before running the unit, otherwise arcing will reduce brush life.

Motor

The motor can be removed without affecting the hydraulic circuit. Undo and remove the two M8 nuts and washers and withdraw the motor. When refitting ensure that the coupling is in place.

Seals

Should service replacement seals be required, a kit is available from your B&G dealer. State the serial number of your unit when ordering.

Bleeding

Special tooling is required to bleed the unit which is available from your B&G dealer. Failure to use the kit may result in damage to the Ram.

FAULT FINDING

WARNING!

Under no circumstances dismantle the unit unless it is certain that the fault is internal. Doing so will allow air into the cylinder, requiring the unit to be bled for which special tools are needed.

Caution!

Any damage to the piston rod will damage its seals and allow air into the cylinder.

1) Motor does not run

- Check electrical connections.
- Check autopilot output.
- Check motor brushes.

2) Motor runs, but erratic or no piston movement

- Check for solenoid operation.
- Check for air in the cylinder -obviated by external oil loss.
- Check drive coupling.

3) Excessive noise from the pump

- Check the motor for damage.
- Check for air in the cylinder -obviated by external oil loss.
- Check drive coupling.

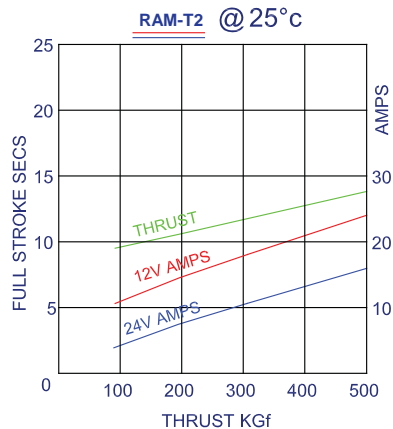
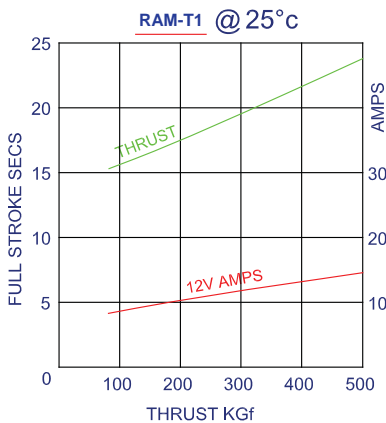

TECHNICAL DATA

Performance

Maximum thrust (intermittent)	675 kg
Hard over time nominal RAM-T1	13 sec
Hard over time nominal RAM-T2	9 sec
Temperature rating minimum	-20°C
Temperature rating maximum	+65°C
Relief valve setting	62 bar
Back-drive at 12 sec Hard-over	7kg

Electrical

Motor voltage nominal	12 or 24v DC
Motor power	100 watt
Max current 12v 25% duty	22.5 A
Max current 24v 25% duty	11.2 A
Rotation	Reversing
Protection	IP44
Connection	1m 2 Core Flying Lead
Ignition protection	BS EN 28846:1993
Coil power continuous	12 watt
Connection	DIN 43650

Recommended oil

Mineral based hydraulic	ISO VG10
-------------------------	----------

Materials

Body	Aluminium BS 1490
Piston rod	Chrome Plated Stainless Steel
Seals	Nitrile & PTFE
Body Protection	SP270
Weight	7.8 kg

GENERAL DIMENSIONS

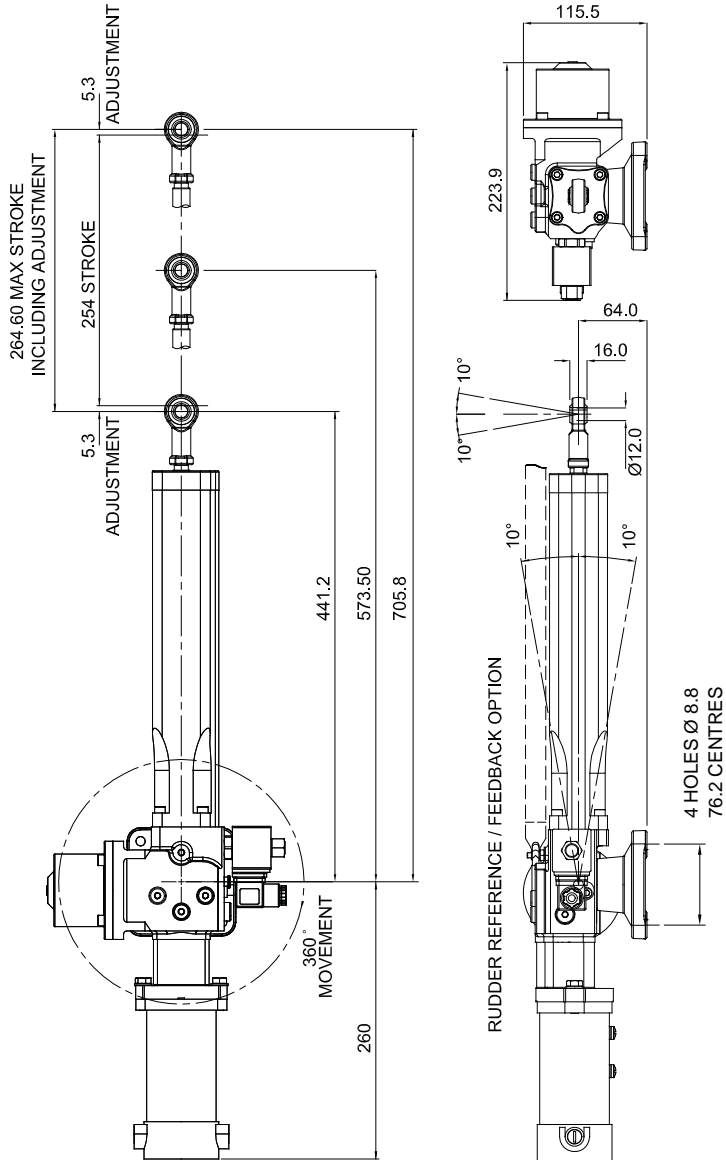

INSTALLATION DETAILS

Tiller Arm

Showing a typical installation for a 214mm (8.4") tiller arm with total rudder angle of 70°

Considerations

Ensure that piston movement is limited by the rudder end-stops and not by the Ram end-stops.

Check that no part of the Ram fouls the structure of the vessel or tiller arm throughout its full range of movement.

Allow sufficient clearance for removal of the mounting pin.

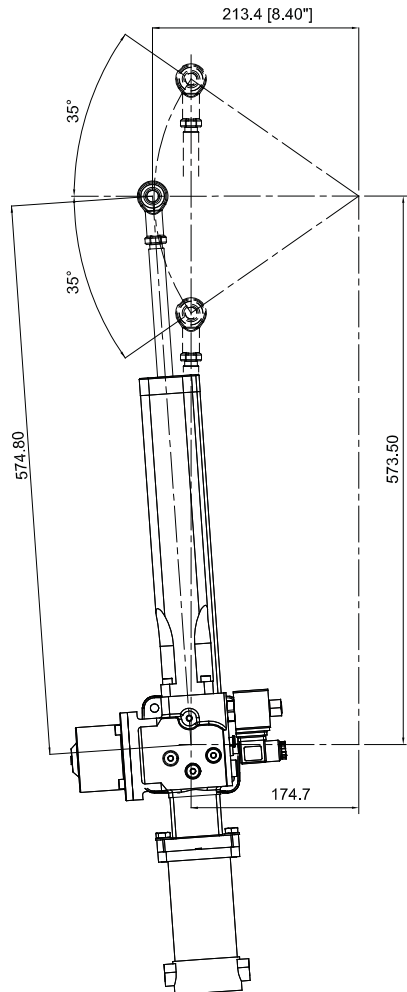

TILLER BOLT

The tiller bolt supplied is suitable for a quadrant thickness of 12 to 16mm.

The tiller bolt mounting hole should be drilled $\text{\O}12.2$ to 12.3mm .

An application of Loctite 638 or equivalent where shown is recommended.

Tighten the M12 nut to 27Nm Torque.

MOUNTING FOOT

The four M8 nuts, bolts and washers supplied are suitable for mounting the Ram onto a surface of between 12mm and 24mm thick.

Tighten the four M8 nuts to 17Nm.

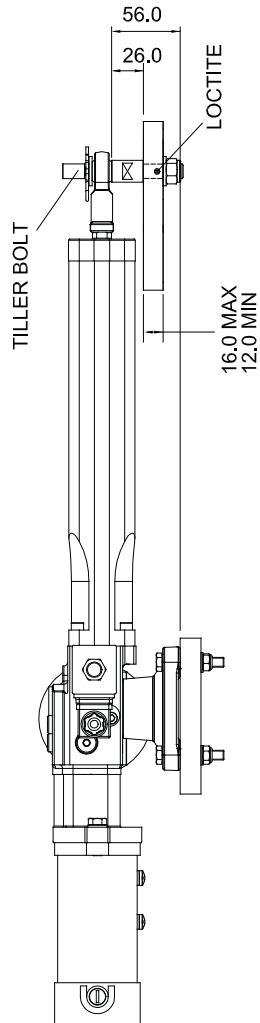

TEMPLATE DIMENSIONS FOR MOUNTING FOOT

Warning!

The template shown below is not to scale! All dimensions listed are correct.

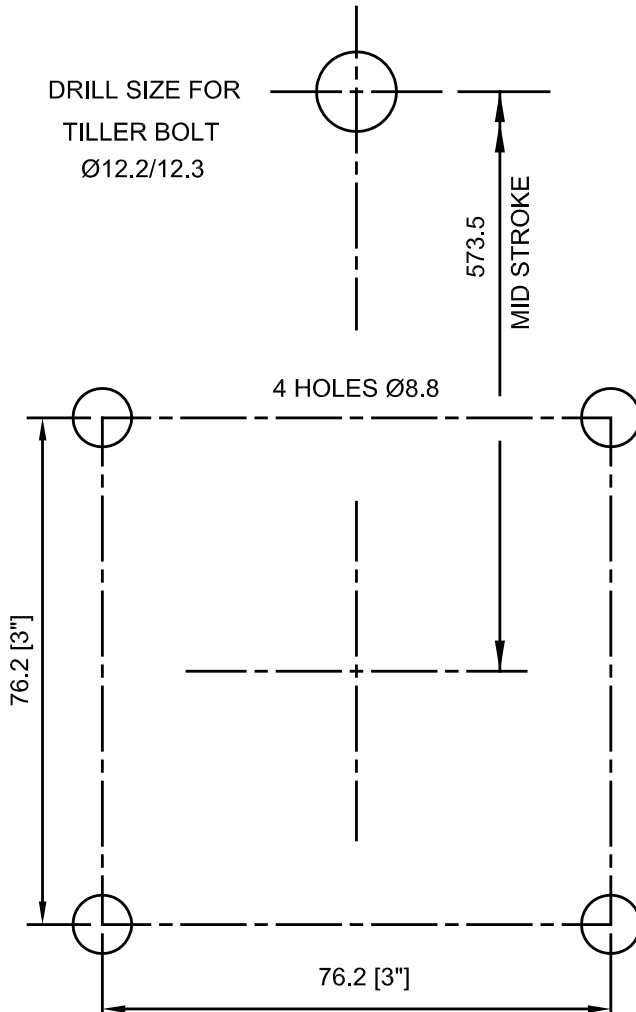

GENERAL INFORMATION

Keep this handbook in a safe place. Quote the model and serial numbers in all correspondence.

Model Number: _____

Serial Number: _____

Date of Purchase: _____

Dealer:

Please dispose of End of Life items responsibly.

In the event that you are unable to use your nearest local authority civic amenity sites to recycle, units can be returned to B&G via an authorised dealer.

